

# Radiator air vents and drainage devices

## series 505 - 5054 - 5055 - 5080 - 560



cert. n° 0003  
ISO 9001

01056/01 GB



### Function

Two types of device are covered here:

- Automatic or manual air vent valves.
- Radiator drain valve with extractor drain tube.

The purpose of the radiator air vent valve is to remove, either manually or automatically, any air trapped inside the heat emitters both during the filling of the system and in normal operation.

The drain valve, on the other hand, makes it possible to easily discharge the water contained in the radiator, thanks to the extractor which is inserted into the valve itself.

### Product range

Series 505	Manual radiator air vent valve	Sizes 1/8", 1/4", 3/8" M
Series 5054	Manual radiator air vent valve with revolving discharge	Sizes 1/8", 1/4", 3/8" M
Series 5055	Manual radiator air vent valve with soft seat	Sizes 1/8", 1/4", 3/8", 1/2" M
Series 5080	Automatic hygroscopic radiator air vent valve	Sizes 1/8", 1/4", 3/8", 1/2" M
Code 560421	Radiator drain valve	Size 1/2" M
Code 560000	Extractor drain tube	

### Technical specification

series ⇨	505 / 5054	5055	5080	560421
<b>Materials:</b>				
- Body:	brass UNI EN 12164 CW614N; nickel plated	brass UNI EN 12164 CW614N; nickel plated	brass UNI EN 12164 CW614N; nickel plated	brass UNI EN 12164 CW614N; nickel plated
- Knob:	POM white RAL 9010	POM white RAL 9010	POM white RAL 9010	
- Outer seal:	PTFE	PTFE	PTFE	EPDM
<b>Performance:</b>				
- Max working pressure:	10 bar	10 bar	10 bar	10 bar
- Max working temperature:	90°C	90°C	100°C	100°C

## Dimensions

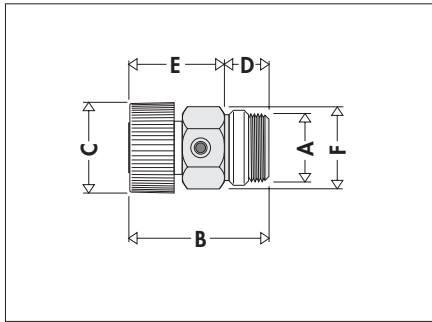

Code	A	B	C	D	E	F
505111	1/8"	29	18	7	22	Es.13
505121	1/4"	29	18	7	22	Es.13
505131	3/8"	32	18	7	25	Es.17

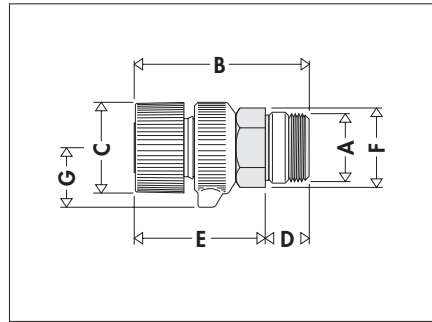

Code	A	B	C	D	E	F	G
505411	1/8"	36,5	18	7	29,5	Es.13	12
505421	1/4"	36,5	18	7	29,5	Es.13	12
505431	3/8"	37	18	7	30	Es.17	12

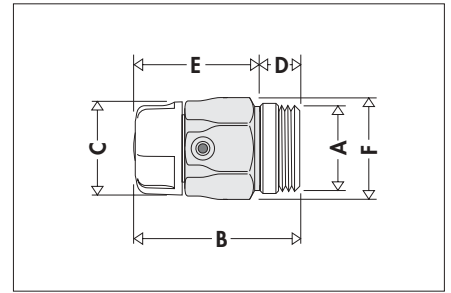

Code	A	B	C	D	E	F
505511	1/8"	30	18	7	23	Es.14
505521	1/4"	30	18	7	23	Es.14
505531	3/8"	33	18	7	26	Es.17
505541	1/2"	35	18	10	25	Es.17

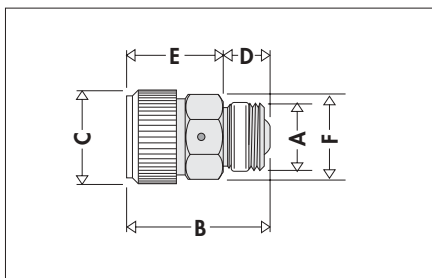

Code	A	B	C	D	E	F
508011	1/8"	30	18	10	20	Es.15
508021	1/4"	30	18	10	20	Es.15
508031	3/8"	30,5	18	10,5	20	Es.17
508041	1/2"	33	18	10	23	Es.17

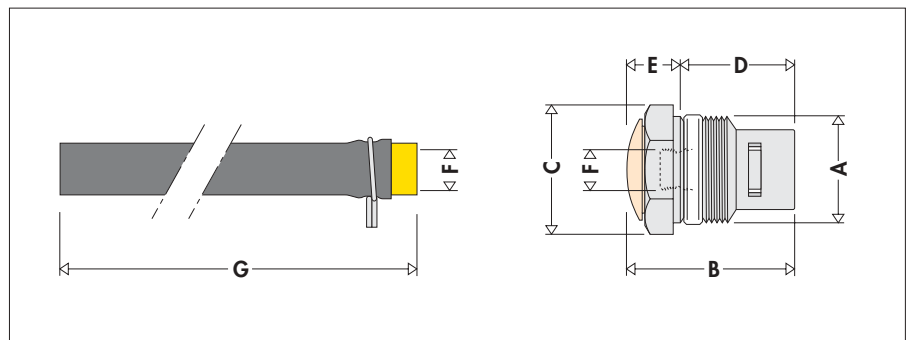

Code	A	B	C	D	E	F	G
560421	1/2"	32,5	Es.22	21,5	11	8 p. 1	-
560000	-	-	-	-	-	8 p. 1	205

## Operating principle / Construction details

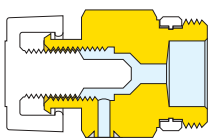

### 505

Valve 505 operates manually. The knob is turned until the air in the heat emitter is completely expelled and water starts to come out.

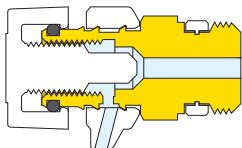

### 5054

This valve operates in the same way as the series 505, but differs in having a 360° revolving discharge facility which makes air venting easier.

### 5055 (REG. MOD.)

Once again, this model operates in the same way as the previous two. The identifying detail of this valve is an internal seal in a special elastic material which provides a tight seal in relation to limited tightening of the knob and possible temperature changes.

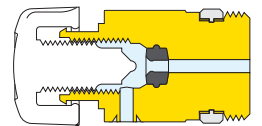

The knob of the valve is shaped so as to be similar in appearance to Caleffi thermostatic valve heads, which enhances the uniformity of the range of radiator components.

### 5080

Valve code 5080 can be used manually or automatically.

The principle of **manual** discharge is the same as for the valves already described, whilst **automatic** discharge is based on the property of the cellulose fibre discs forming the seal cartridge.

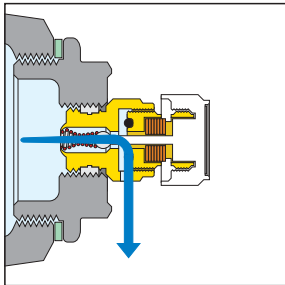
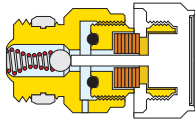

The **manual** discharge position is achieved by unscrewing the knob **approx. one turn**. Typical use of this method is when refilling the system.

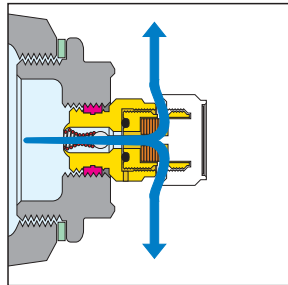

The **automatic** discharge position, however, is achieved with the knob fully closed.

The hygroscopic discs increase their volume by 50% when they are immersed in water.

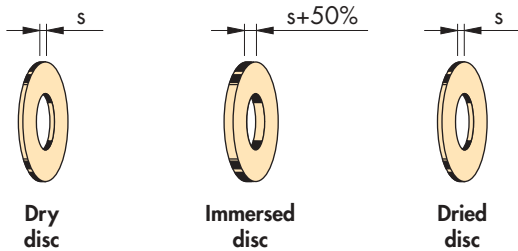

In this way, when the system is operating under normal conditions, the discs are immersed and, thanks to their increase in volume, they close the valve. However, when air is present, the discs dry out and allow the air to vent.

The hygroscopic discs close very quickly, in just a few seconds. The drying times are such that there are no problems with the cycle of formation and elimination of air.

#### Table of drying times

Water temperature °C	40	50	60	70	80	90	100
Times in hours	6	5	2 1/2	1 1/2	1	1/2	1/4

#### Replaceable cartridge

The valve is constructed in such a way that the part containing the hygroscopic discs can easily be replaced without having to empty the heat emitter. This may be necessary because the discs can deteriorate in time if there is unfiltered or hard water present.

It is, in any case, advisable to replace the disc cartridge at least every 36 months.

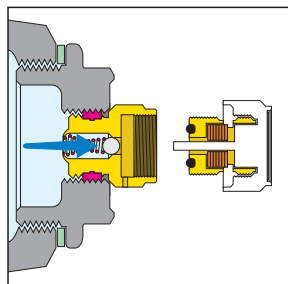

### 560

The drain valve is applied to the lower connection of the radiator. When inserting the extractor drain tube into the valve itself, the sliding piston which provides the outer seal must be screw-located and extracted, making the water flow outwards.

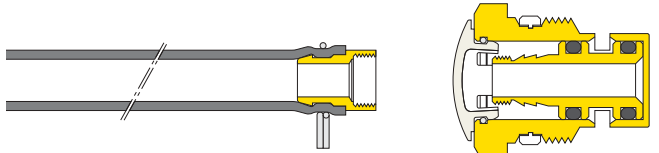

Valve closed

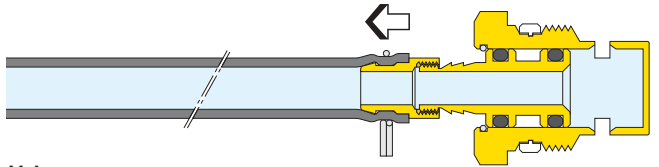

Valve open

#### Use of the series 560 drain valve



**1** Remove protective cap



**2** Screw on the drain tube provided



**3** Pull out the tube, turning it into a basin.

## SPECIFICATION SUMMARIES

### Series 505

Radiator air vent valve. Threaded connection 1/8" M (from 1/8" to 3/8") with PTFE seal. Brass body. Nickel plated. White heat resistant knob in POM. Max working temperature 90°C. Max working pressure 10 bar.

### Series 5054

Radiator air vent valve. Threaded connection 1/8" M (from 1/8" to 3/8") with PTFE seal. Brass body. Nickel plated. White heat resistant knob in POM. Max working temperature 90°C. Max working pressure 10 bar. Rotable outlet.

### Series 5055

Radiator air vent valve with EPDM soft seal. Threaded connection 1/8" M (from 1/8" to 1/2") with PTFE seal. Brass body. Nickel plated. White heat resistant knob in POM. Max working temperature 90°C. Max working pressure 10 bar.

### Series 5080

Automatic hygroscopic air vent valve. Threaded connection 1/8" M (from 1/8" to 1/2") with PTFE seal. Brass body. Nickel plated. White heat resistant knob in POM. Max working temperature 100°C. Max working pressure 10 bar. Replaceable hygroscopic cartridge.

### Code 560421

Radiator drain valve. Threaded connection 1/2" M. EPDM seal. Brass body. Nickel plated. Max working temperature 100°C. Max working pressure 10 bar. Designed for use with extractor drain tube.

### Code 560000

Extractor drain tube for extraction of sliding piston from radiator drain valve.